



From in-clinic to dedicated high-production labs, the DWX-42W is engineered to fit your milling needs.



### Incredibly Accurate, High Aesthetic Restorations

Designed for wet milling pin-type materials including glass ceramic, composite resins, PMMA and sintered zirconia. Produce high quality restorations including crowns, copings, 3-unit bridges, inlays, and, onlays. Titanium alloy abutment blanks can now be milled with the optional AK-1 abutment milling kit (sold separately).

### Elevated Performance

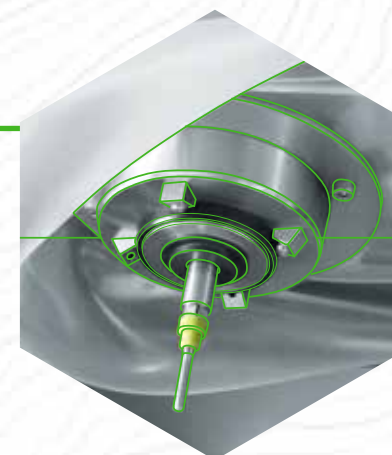
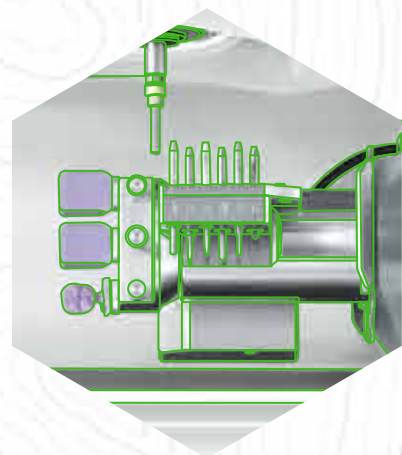

-  **6-Station Automatic Tool Changer (ATC)** for uninterrupted production
-  Brand new burs offer **GREATER STABILITY & FINE MILLING QUALITY**
-  Newly designed **NOZZLES & COOLANT TANK** for greater flow and capacity
-  **50% FASTER** than the previous generation DGSHAPE wet mill



### Specially Designed Spindle

**▼ 50% LESS**  
Air Pressure Needed

Optimum performance with less air pressure and volume



-  Designed and built by DGSHAPE—using over 35-years of cutting-edge engineering excellence
-  A robust, all metal spindle offers solid performance and maximum efficiency
-  Doesn't require a high-volume compressor—perfect for in-clinic labs

### A Mill That Fits Your Needs

- #### High Production Lab
- Expand production by adding a standalone wet-milling option designed for glass ceramics, composite resins, PMMA and sintered zirconia materials
  - Get the same open architecture flexibility and high-quality performance as DGSHAPE dry mills, in a wet-milling configuration
  - On-demand production of high-esthetic, dental prosthetics

- #### In-Clinic Lab
- Offer your patients a same day service with ultra-accurate prosthetics—produced with an easy-to-operate machine and simplified workflow
  - Open architecture allows seamless integration with existing scanning devices
  - Gain revenue with a simple, easy to maintain mill

### Enhanced User Experience

-  **New Ethernet LAN Connectivity**  
Access your device and manage your milling, anywhere in the lab or office.
-  **Upgraded V-Panel**  
Complex controls are replaced with an easy interface to monitor milling jobs and tool life.
-  **Multi-CAM Software Compatible**  
Compatible with open-architecture CAM software to accept all STL files.





Wet Dental Mill  
**DWX-42W**

- Uninterrupted wet milling with ultimate precision and accuracy.**
- Up to three different blocks of glass ceramic, composite resin, PMMA and sintered zirconia
  - Titanium abutment blanks with the optional AK-1 abutment milling kit

Specifications	
<b>Millable material</b>	Glass ceramics, Titanium alloy, composite resins, PMMA, Sintered Zirconia
<b>Loadable workpiece shape</b>	Width: Maximum 40 mm (1.57 in)
	Depth: Maximum 20 mm (0.79 in)
	Height: Maximum 20 mm (0.79 in)
<b>Operating speed</b>	6 to 1,800 mm/min. (0.24 to 70.9 in./min.)
<b>Spindle speed</b>	15,000 to 60,000 rpm
<b>Rotary axis travel angle</b>	A: ±360°
<b>Number of burs housed</b>	6
<b>Attachable bur</b>	Shank diameter: 3 mm, dedicated milling bur
<b>Compatible compressed air</b>	Pressure: 0.18 to 0.22 MPA
	Air Capacity: 114L/min (30gal) or more
	Tank Capacity: 33L (8.7gal) or more
<b>Interface</b>	USB, Ethernet (10 BASE-T/100 BASE-TX automatic switching)
<b>Control command set</b>	RML-1, NC code
<b>Power requirements</b>	AC 100 to 240 V ± 10%, 50/60 Hz (overvoltage category II, IEC 60664-1), 2.1 A
<b>Power consumption</b>	Approximately 190 W
<b>Operating noise</b>	During operation : 70 dB(A) or less (when not cutting), During standby: 48 dB(A) or less
<b>External dimensions</b>	Width x Depth x Height: 482 x 560 x 600 mm (19.0 x 22.0 x 23.6 in.)
<b>Weight</b>	61 kg (135 lbs.)
<b>Installation environment</b>	Indoor use, Altitude: Up to 6,562 ft. (2,000m), Temperature: 41 to 82 °F (5 to 28°C), Humidity: 35 to 80%RH (no condensation), Ambient pollution degree: 2 (as specified by IEC 60664-1), Short-term temporary overvoltage: 1,440 V, Long-term temporary overvoltage: 490 V
<b>Included items</b>	Power cord, USB cable, Dedicated milling burs, Automatic correction jig, Measuring cup, Hexagonal screwdriver, Hexagonal wrench, etc.

**DGSHAPE Brand Promise**

DGSHAPE is the brand name of the 3D business unit spun off from Roland DG with the core mission: "make innovation, make life better." DGSHAPE delivers digital technologies that bring ideas to life, revolutionize business processes, and shape a better future. Our goal is to fuse human creativity with digital workflows to provide exceptional value across multiple endeavors, from individual craftsmanship to manufacturing, healthcare and beyond.

**About DGSHAPE**

DGSHAPE Corporation was spun-off of Roland DG Corporation in 2017 as a wholly-owned subsidiary to develop and market the company's innovative 3D products, including DWX mills and DWP 3D printer for the dental industry, MPX photo impact printers, and EGX engravers for the industrial labeling and personalization industries, and MDX and monoFab series of desktop milling machines for the rapid prototyping, manufacturing, and hobby industries. DGSHAPE products are distributed worldwide.

To learn more, visit [www.dgshape.com/product/DWX-42W](http://www.dgshape.com/product/DWX-42W)

Get social with us.



FOR MORE INFORMATION OR TO FIND A DEALER NEAR YOU, VISIT [WWW.DGSHAPE.COM](http://WWW.DGSHAPE.COM)  
 DGSHAPE CORPORATION | 1-6-4 SHINMIYAKODA, KITA-KU, HAMAMATSU-SHI, SHIZUOKA-KEN, 431-2103 JAPAN | PHONE: +81-53-482-7069

Roland DG's international ISO certifications are your assurance of our commitment to quality products and service | Roland DGA Corp. has licensed the MMP technology from the TPL Group.

**Intelligent Machine.  
Effortless Production.  
Superior Results.**



Wet Dental Mill  
**DWX-42W**